

Investigation of the Performance of Direct AC to AC Converter in High Frequency Industrial Applications

¹JBV Subrahmanyam, ²TC Subramanyam, ³TC Srinivasarao

^{1,2}Electrical & Electronics Engineering Dept.,
Bharat Institute of Engineering & Technology (BIET), mangalpally, ibrahimpatnam,
RR district, Hyderabad, AP, INDIA 501 510
Electrical & Electronics Engineering

³Dept., Vardhaman college of engineering, kacharam(v),
shamshabad, Hyderabad, AP, INDIA

ABSTRACT

The purpose of the study is to investigate the performance of the direct AC to AC converter in high frequency applications and analyze AC to AC Matrix Converter having a nine switch topology with hysteresis controller using MATLAB / SIMULINK package. A Matrix Converter with 18 IGBTs and 18 diode achieves the desired variable voltage, variable frequency performance using a two stage circuit. In the first stage three phase normal frequency voltage is converted to single phase high frequency voltage. In second stage three phase variable amplitude variable frequency voltage is generated. Hysteresis controller is implemented to obtain sinusoidal output current. In this paper output frequency realized is 50 Hz. It is possible to set the output to any other frequency also.

Key words: Matrix Converter, Hysteresis Controller, SPWM, IGBTs

I. INTRODUCTION

The oil crisis in the early 70's and the steadily increasing environmental concern have initiated a major interest for the exploitation of renewable sources of energy for the generation of electrical power. Most promising among them appear to be the wind package is used and, at a second level, the solar energy. The main characteristic of these sources, compared with the conventional ones, is that the primary energy flow is stochastic in nature and thus uncontrolled and continuously fluctuating, which is particularly true for the wind. Therefore, special schemes and control procedures have to be developed and implemented for the regulation of the produced electrical power and the maximization of the capture of the available energy. With the recent developments in the power electronics, low-cost, high-reliability and efficiency converters are available for wind turbine applications. The utilization of advanced power conversion schemes and sophisticated controllers presents an increasing interest, since it improves the energy production and the quality of operation of the plants.

Direct AC to AC power conversion without the use of intermediate energy storage [1] is achieved by a Matrix Converter (MC) for connection to grid with input as wind turbine generator shown in fig 1. The absence of energy storage devices makes the Matrix Converters to be compact and permits them to be readily integrated into drive systems as opposed to traditional ac to ac converters which are usually bulky. The static AC to AC Matrix Converters use a four out put leg topology in order to eliminate the need for DC link capacitors. Recently there

has been considerable interest in the Matrix Converter technology due to the potential benefits it offers especially in applications where size, weight, and long-term reliability are important factors. Since there is no need for stored energy in the Matrix Converter the potential drop at high power densities is absent as is the case with many existing solutions. This Converter is also inherently bidirectional, so it can regenerate energy back to the utility [2]. In spite of all the rewards of using MC in a motor drive system, it has major disadvantage is that the output voltage of a MC is limited to 86% of the input.

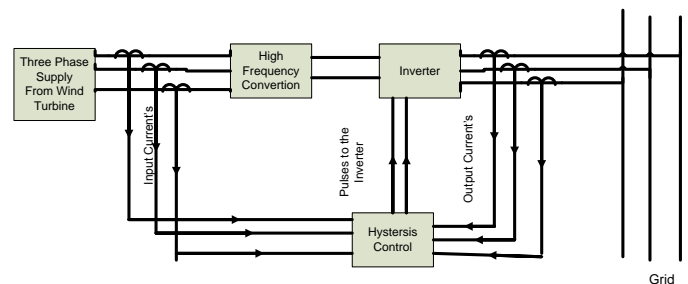

Fig 1: Block Diagram of Matrix Converter with Hysteresis Controller

This paper investigates the performance of the direct AC to AC converter in high frequency applications. The role of high frequency link is analyzed since this type of link provides galvanic isolation and also acts as a power conditioner in some of the typical applications. Detailed simulation has been carried out with hysteresis controller to achieve sinusoidal output current.

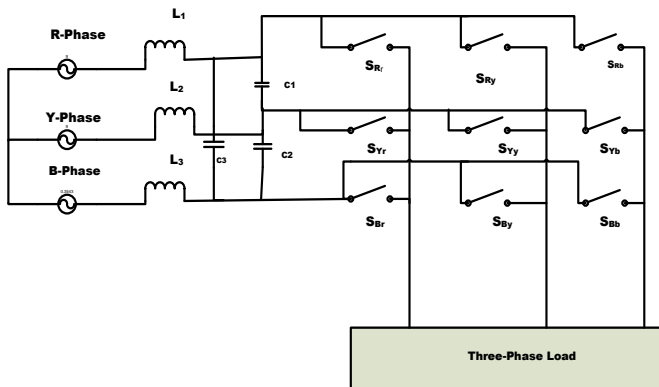

Fig. 2 Matrix Converter Overview

II. MATRIX CONVERTER

Fig 2 shows a schematic diagram of a three phase to three-phase Matrix Converter (MC), for which inputs and outputs are v_a, v_b, v_c and i_a, i_b, i_c respectively. The switching relationship between the input and output is given by:

$$S_{Kj} = \begin{cases} 1, & \text{switch } S_{Kj} \text{ closed} \\ 0, & \text{switch } S_{Kj} \text{ open} \end{cases} \quad (1)$$

Where $K = \{A, B, C\}$, $j = \{a, b, c\}$, and

$$S_{Ka+} \quad S_{Kb+} \quad S_{Kc+} = 1 \quad (2)$$

The relationship between input and output instantaneous phase voltages is given by:

$$\begin{bmatrix} V_R \\ V_Y \\ V_B \end{bmatrix} = \begin{bmatrix} S_{Rr} & S_{Ry} & S_{Rb} \\ S_{Yr} & S_{Yy} & S_{Yb} \\ S_{Br} & S_{By} & S_{Bb} \end{bmatrix} \begin{bmatrix} v_r \\ v_y \\ v_b \end{bmatrix} \quad (3)$$

Where V_R, V_Y, V_B (v_r, v_y, v_b) are the output (input) voltage. Based on above equation (3), line to line voltages and phase currents at the output (input) terminals are given by

$$\begin{bmatrix} V_{RY} \\ V_{YB} \\ V_{BR} \end{bmatrix} = \begin{bmatrix} S_{Rr} - S_{Yr} & S_{Ry} - S_{Yy} & S_{Rb} - S_{Yb} \\ S_{Yr} - S_{Br} & S_{Yy} - S_{By} & S_{Yb} - S_{Bb} \\ S_{Br} - S_{Rr} & S_{By} - S_{Ry} & S_{Bb} - S_{Rb} \end{bmatrix} \begin{bmatrix} v_r \\ v_y \\ v_b \end{bmatrix} \quad (4)$$

$$\begin{bmatrix} i_r \\ i_y \\ i_b \end{bmatrix} = \begin{bmatrix} S_{Rr} & S_{Yr} & S_{Br} \\ S_{Ry} & S_{Yy} & S_{By} \\ S_{Rb} & S_{Yb} & S_{Bb} \end{bmatrix} \begin{bmatrix} I_R \\ I_Y \\ I_B \end{bmatrix} \quad (5)$$

Where V_{RY}, V_{YB}, V_{BR} (I_R, I_Y, I_B) are the output instantaneous voltage (currents), and i_r, i_y, i_b are the instantaneous phase currents.

A. The Proposed Converter and its Control

In this paper, high frequency converter topology is proposed.

It consists of the following two power conversion stages.

- i. **Primary converter:** In this stage fixed frequency utility three phase supply to high frequency single phase conversion is developed.
- ii. **Secondary converter:** In this stage high frequency single phase to three phase variable voltage-variable frequency converter stage is developed.

Using primary converter and secondary converters, three phase normal frequency and normal voltage can be converted into three phase variable voltage variable frequency by using 18 IGBTs and 18 diodes as shown in fig 3. In each bidirectional switch two IGBT's & two diodes are connected in anti parallel direction. Primary converter consists of six bidirectional switches and secondary converter consists of ten unidirectional switches

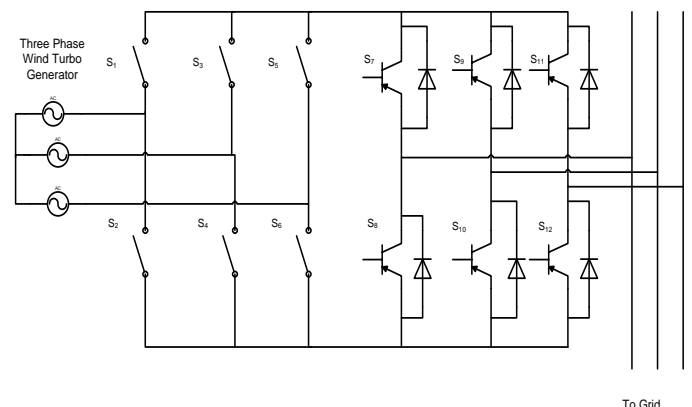

Fig 3 Matrix Converter-Variable Voltage & Frequency

In the secondary converter, switches S_7 to S_{10} are made used for full bridge rectification and S_{11} to S_{16} are used for DC to three phase AC conversion.

B. Analysis of Primary Converter

This primary converter is used to convert normal utility three phase supply voltage which is having fixed frequency to high frequency single phase pulses. This can be achieved by chopping the input voltage in a predetermined manner. The control method is based on the detection of maximum conducting phases for generation of modulation signal. Consider the following balanced set of 3 phase input voltages as shown in the formulae given below.

$$V_r = V_m \sin(2\pi f_{in}t) \quad (6)$$

$$V_y = V_m \sin(2\pi f_{in}t - 2\pi/3) \quad (7)$$

$$V_b = V_m \sin(2\pi f_{in}t + 2\pi/3) \quad (8)$$

Where V_m is the maximum value of input phase voltage and f_{in} is the supply frequency of source.

Initially study the three phase waveforms for one complete cycle (or) 360° and then it can be divided into the six equal parts as shown in the figure 7.

In these six sectors, in each sector one phase can be taken as reference and in the remaining other two phases one phase is increasing from 0° to 60° , the second phase is decreasing from 60° to 0° . For example, let us consider Y phase as a reference phase, then from R phase and B phase's positive & negative cycles can be obtained as given in (9).

$$V_y = V_r + V_b \quad (9)$$

For sector I, for constructing the positive pulses across the transformer switch S_{yn} is turned on for a period $T_{sw}/2$, while S_m & S_{bn} are modulated while all other switches are remain off position. The duty ratio for the switches is calculated as given below.

$$D_r = \frac{|v_r|}{\max(|v_r|, |v_y|, |v_b|)} \quad (10)$$

$$D_y = \frac{|v_y|}{\max(|v_r|, |v_y|, |v_b|)} \quad (11)$$

$$D_b = \frac{|v_b|}{\max(|v_r|, |v_y|, |v_b|)} \quad (12)$$

& output DC voltage is equated as

$$V_{dc} = (D_b(V_y - V_b) + D_r(V_y - V_r)) \quad (13)$$

Negative part of the high frequency wave is generated by forcing S_{yn} to off condition and S_{yp} to turn on

for a next period of $T_{sw} / 2$. The switches S_{bn} and S_{rn} are modulated for this period $T_{sw} / 2$. Hence this converter can be considered as a forced commutated cycloconverter and its implementation is possible due to availability of semiconductors as IGBTs, MCTS etc. Similarly the whole sequence of generation of high frequency pulses and conduction of bidirectional switches can be tabulated [8-12] as given in table 1.

Table 1: Switching Sequence for High Frequency Conversion

S.No	Reference Phase	Positive Cycle	Negative Cycle
1	Negative Y Phase	S_3, S_6	S_4, S_1
2	Positive R Phase	S_1, S_4	S_2, S_5
3	Negative B Phase	S_5, S_2	S_6, S_3
4	Positive Y Phase	S_4, S_1	S_3, S_6
5	Negative R Phase	S_2, S_5	S_1, S_4
6	Positive B Phase	S_6, S_3	S_5, S_2

In the first sector I, for positive half cycle switches S_3 & S_6 conducts, all other four switches are in off condition and power flows from S_3 to S_6 as shown in fig 4.

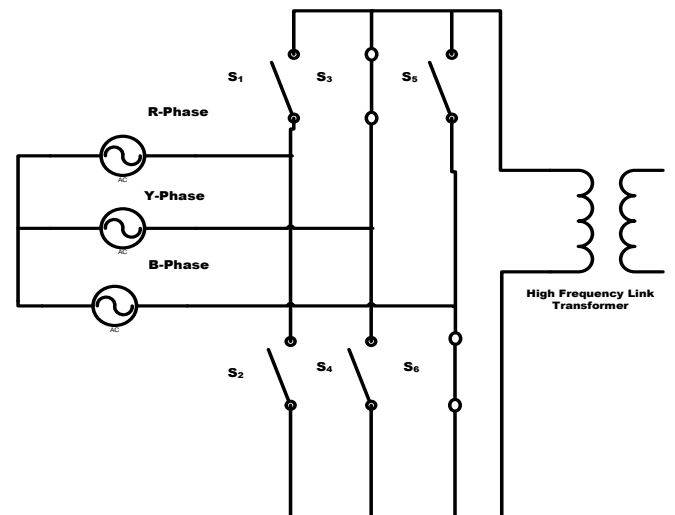

Fig 4: High Frequency Positive Conducting Cycle - Sector I

In this case the duty cycle can be taken as 50% of the total time period. In the negative half cycle for the sector 1, switches S_4 & S_1 conduct, all other switches are in off condition as shown in fig 5. In this case also the duty cycle will be the remaining 50% of the total time period.

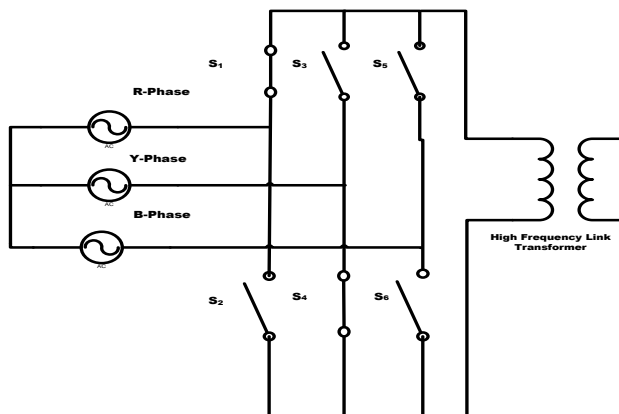

Fig. 5: High Frequency Negative Conducting Cycle- Sector I

C. Analysis of Secondary Converter

The main purpose of this converter is to provide variable voltage, variable frequency from the single phase high frequency. In this secondary converter 6 unidirectional switches S_7 to S_{12} are used for the inversion.

Here SPWM is used to convert Pulsating DC to AC, in each case three switches can be operating at a time one from positive and two from negative or vice versa as mentioned in the table 2.

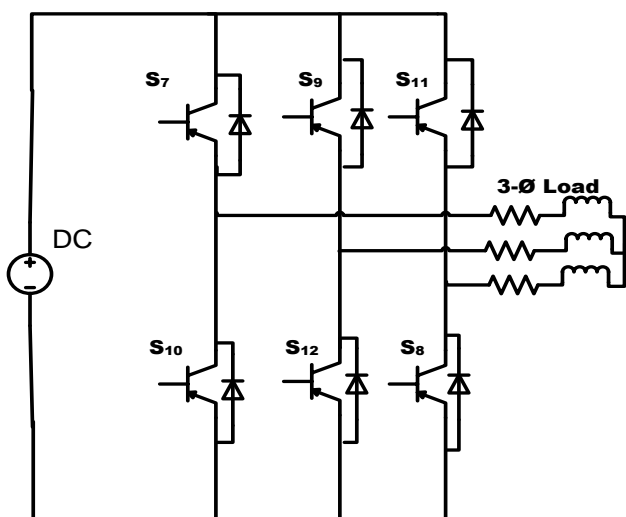

Fig 6: Circuit Diagram of Inversion

Table 2: Inverter Switching States

Switch Condition	State No	V_{ab}	V_{bc}	V_{ca}
S_7, S_{11} and S_{12} are on and S_{10}, S_8 and S_9 are off	1	V_i	0	$-V_i$

S_8, S_9 and S_7 are on and S_{11}, S_{12} and S_{10} are off	2	0	V_i	$-V_i$
S_9, S_7 and S_8 are on and S_{12}, S_{10} and S_{11} are off	3	$-V_i$	V_i	0
S_{10}, S_8 and S_9 are on and S_{15}, S_{11} and S_{16} are off	4	$-V_i$	0	V_i
S_{12}, S_{10} and S_{11} are on and S_9, S_7 and S_8 are off	5	0	$-V_i$	V_i
S_{12}, S_{10} and S_{11} are on and S_9, S_7 and S_8 are off	6	V_i	$-V_i$	0
S_7, S_9 and S_{11} are on and S_8, S_{10} and S_{12} are off	7	0	0	0
S_8, S_{10} and S_{12} are on and S_7, S_9 and S_{11} are off	8	0	0	0

Out of eight switching states only six switching states are useful for getting required output, the other two switching states 7 and 8 are not useful for inversion because in 7th switching state as shown in the table 2 only upper case switches are conducting and in 8th switching state only lower case switches are conducting so that it does not provide closed path in fig 6.

III. SIMULATION RESULTS AND DISCUSSION

In this Matrix Converter SPWM technique with Hysteresis Controller is used. In this Hysteresis Controller, the output current wave is compared with the input current sine wave and then it is compared with upper and lower hysteresis bands to obtain required pluses to the inverter and hence to achieve sinusoidal current waveform. The performance of this Matrix Converter has been demonstrated by simulations using Mat lab /Simulink. The wave forms of high frequency voltage, input current & output current waveforms are shown in the fig 8, fig 9, fig 10 respectively

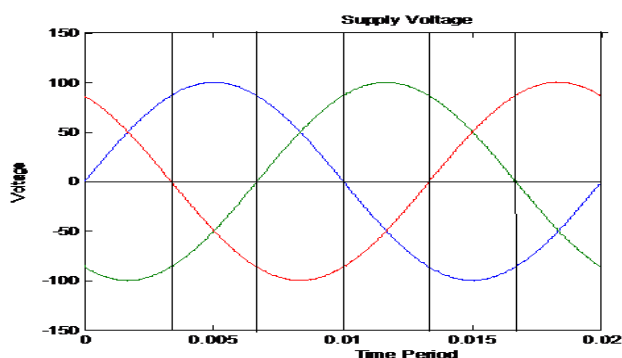

Fig 7: Three Phase Input Supply voltage Wave Form

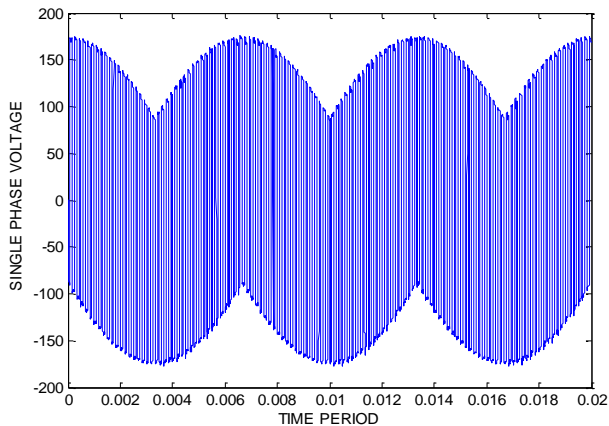

Fig 8: Single phase high frequency voltage waveform

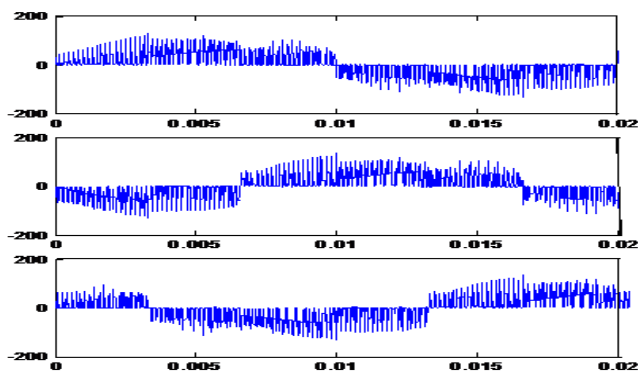

Fig 9: Input Current Wave forms

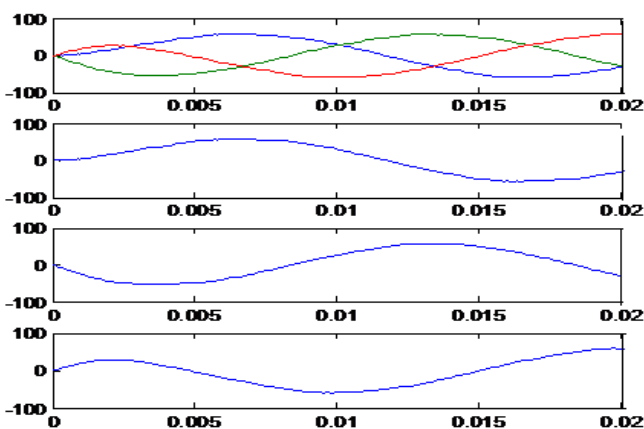

Fig 10: Output Current Waveforms

IV. CONCLUSION

Direct AC to AC Conversion in high frequency applications with Variable Frequency Sinusoidal input/output currents is achieved. This scheme of AC/AC converter is well suited in case of a windmill prime mover connected to an alternator. Wind mill speed is continuously changes depend on the wind speed and the volume of wind displaced by wind mill. Through this

scheme as inter face wind mill power can fed to power system grid. Grid Connected Wind Generators is achieved without dc stage (no storage elements) with Hysteresis Controller.

V. ACKNOWLEDGEMENT

Authors acknowledge the support and facilities provided by the Electrical & Electronics Engineering Department and management of Bharat Institute of Engineering & Technology, Mangalpally, ibrahimpatnam,Hyderabad,AP, India in carryout the presented study/research work.

REFERENCES

- [1] P. W. Wheeler, L. Empringham, M. Bland "A Utility Power Supply Based on a Four-Output Leg Matrix Converter", IEEE Transactions On Industry Applications, Vol. 44, No. 1, January/February 2008, pg 174-186.
- [2] Thiwanka Wijekoon,Pericle Zanchetta "Implementation Of Hybrid AC-AC Direct Power Converter With Unity Power Factor ",IEEE Transaction On Power Electronics,vol.23,no.4,pg 1918-1928.
- [3] Fang Gao,M.Renza Iravani " Dynamic Model Of A Space Vector Modulated Matrix Converter ",IEEE Transaction On Power Delivery, Vol.22, no.3, July2008, pg .1696-1705.
- [4] Simon D.Round, Hans Ertl "Novel Three-Phase AC-AC Sparse Matrix Converter" IEEE Transaction On Power Electronics, Vol.22, No.5, September 2007,Pg 1649-1661.
- [5] Peter Mutschler "A Direct Control Method for Matrix Converters" IEEE Tran on Industrial Electronics, Vol. 49, no. 2, April 2002, pg 362-369.
- [6] Patrick Wheeler, Jon Clare, Lee Empringham, Maurice Apap and Michael Bland "matrix converters "Power Engineering Journal, December 2002, pg 273-282.
- [7] R. Erickson, S. Angkititrakul, and K. Almazeedi "A New Family of Multilevel Matrix Converters for Wind Power Applications: Final Report" *University of Colorado Boulder, Colorado*, NREL Technical Monitor: Alan Laxson, December 2006, pg 15-67.
- [8] MaÁngeles Martín Prats, L. G. Franquelo "A 3-D Space Vector Modulation generalize Algorithm



- for Multilevel Converters” IEEE Power Electronics Letters, Vol. 1, No. 4, December 2003, pg 110-115.
- [9] Lars Helle, Kim B. Larsen, Allan Holm Jorgensen, Stig Munk-Nielsen “Evaluation of Modulation Schemes for Three-Phase to Three-Phase Matrix Converters” IEEE Transactions On Industrial Electronics, Vol. 51, No. 1, February 2004, pg 158-171.
- [10] Patrick W. Wheeler, Jon C. Clare, Michael Bland “Gate Drive Level Intelligence and Current Sensing for Matrix Converter Current Commutation” IEEE Transactions On Industrial Electronics, Vol. 49, No. 2, April 2002,pg 382-389.
- [11] L. Huber, D. Borzjovic “Space Vector Modulated Three-phase to Three-phase Matrix Converter with Input Power Factor Correction” IEEE Transactions On Industry Applications, Vol. 31, No 6, November December 1995,pg 1234-1246.
- [12] A. Zuckerman, D. Weinstein, A. Alexandrovitz “simulation of three-phase loaded matrix converter” IEEE Transaction on.-Elec. Power App/. *vo/. 143, No. 4, July 1996, pg 294-300.*